



**WTS-A Room Temperature Sensor with Override & Slider Setpoint**

The WTS family of Wall Temperature Sensors are designed to be used with the M2 family of Solidyne controllers. They are designed with a rugged anodized aluminum housing and a unique one screw attachment to its base plate.

The WTS-A has a push button on the face of the sensor for zone override and a 10k thermistor for temperature sensing. A slider 10k potentiometer is used for zone setpoint. The WTS-A can either be wired via CAT-5 and RJ-45 cabling or using 3 conductor cabling.

**Specifications**

- Input Power:** Supplied by M2 controller
- Temperature Input:** 10k Thermistor (Type III)
- Slider Setpoint:** 10k potentiometer (configure Input as ZTS-A)
- Override Button:** Shorts temperature input
- Operating Temperature:** +23°F to +150°F (-5°C to +66°C)
- Storage Temperature:** -40°F to +230°F (-40°C to +110°C)
- Operating Humidity:** 10 to 95 %RH non-condensing
- Storage Humidity:** 10 to 95 %RH non-condensing

**Physical Dimensions**

**WTS-A Housing:**

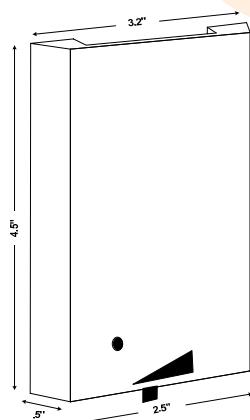

**Figure 1**

**WTS-A Backplate:**

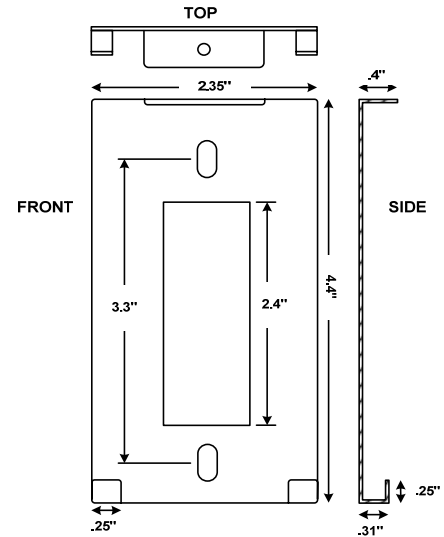
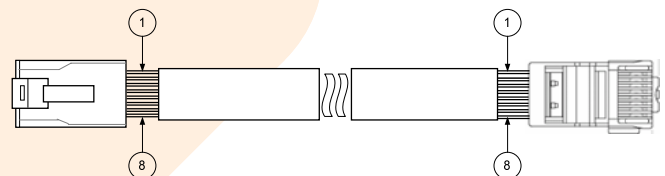

**Figure 2**

**Wiring**

The WTS-A can be wired to an M2 family controller in 2 ways. The first would be via the CAT-5 connection on the back of the device. This method uses any straight through CAT-5 cable. See figure 3 for the proper RJ-45 crimping polarity. One end of the CAT-5 cable terminates into either of the two RJ-45 female connectors on the back of the WTS-A. The other end will terminate into the middle M2 RJ-45 female connector. When the WTS-A is wired via this method, the temperature sensor input will automatically use Input #1 (AI1) of the M2 controller that it is attached. The slider setpoint input will automatically use Input #2 (AI2) on an M2 and Input #3 (ADJ) on an M2V controller.

The second method is to hard wire the WTS-A to any of the inputs (AI) of the M2 family of controllers. The WTS-A has a 3 position screw terminal block where only 3 wires are needed to properly connect the WTS-A to any of the M2 inputs.



**Figure 3**

## Wiring Cont'd

### CAT-5 Wiring:

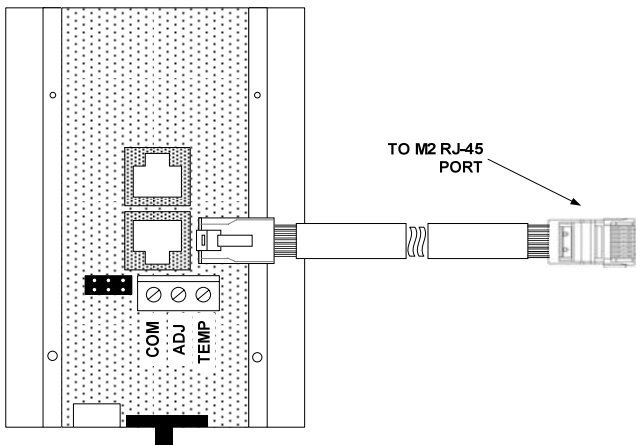

Figure 4

### CAT-5 Input Assignment:

When using the CAT-5 wiring, the M2 controllers will automatically assign its inputs to pre-defined locations:

	M2	M2V
Temperature Sensor	Input 1 (AI1)	Input 1 (Zone Temp)
Slider Setpoint	Input 2 (AI2)	Input 3 (ADJ)

Table 1

### Hard Wiring:

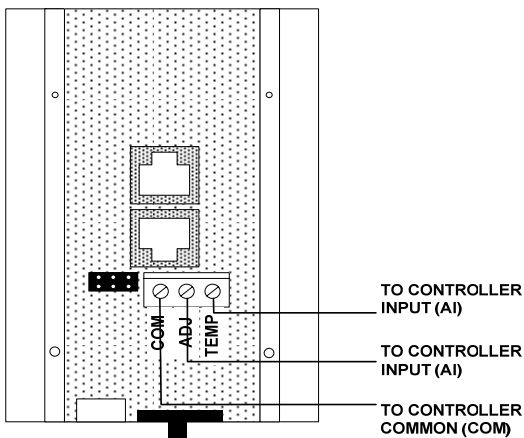

Figure 5

When hard wiring the WTS-A, Solidyne recommends using 18ga shielded conductors.

## Slider Setpoint Input Configuration

The slider setpoint should be configured as a Type ZTS-A which will have the setpoint range value of 55 to 85 which can be adjusted with the input's multiplier and offset for your desired range.

© Copyright 2005 Solidyne Corporation All rights reserved.

No part of this document may be photocopied or reproduced by any means, or translated to another language without prior written consent of Solidyne.

All specifications are nominal and may change as design improvements are introduced. Solidyne shall not be liable for damages resulting from misapplication or misuse of its products.

## Jumper Configuration

The WTS-A has 3 jumper configurations. The default jumper position is JP2 only. Other jumper configurations are reserved for future use and not applicable at this time.

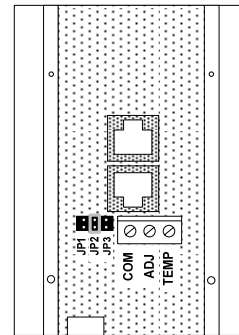

Figure 6

## M2-HH Commissioning Tool

The WTS-A has a small 5 pin connector on the bottom end of the device which is used to connect the M2-HH hand held commissioning tool. Please see the 00-M2-HH documentation for more information.

## Installation

The WTS-A backplate will install easily onto any 2"x4" electrical box with the supplied 1" screws. An electrical box is not necessary for proper installation of the WTS-A. The 1" screws have a flat head, if longer screws are needed, please make sure they have a flat head.

Once the backplate is installed and wiring is completed, install the WTS-A sensor onto the backplate at an angle starting at the bottom of the sensor as shown in figure 7.

After sliding the WTS-A sensor onto the support bracket of the backplate, rotate the sensor towards the wall and secure the WTS-A sensor in place by installing the supplied set screw as shown in figure 8.

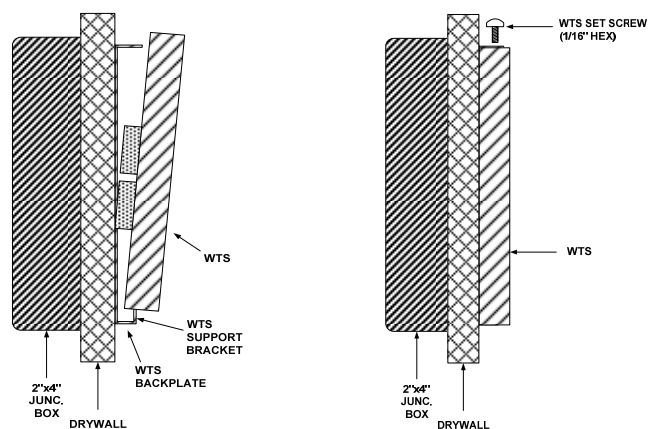

Figure 7

Figure 8